

Lurgi

sasol
reaching new frontiers



**Update on the Sasol-Lurgi Technology Company
Business Activities and the application of the S-L
FBDB Gasification Technology**

**(incl. an Overview of Sasol's CTL Business
Activities)**

Presentation to the:
2007 Gasification Technologies Conference
15-17 October 2007, San Francisco, CA

**Eric van de Venter, MD SLTC
on behalf of Sasol-Lurgi Technology Company
Email: eric.vandeventer@sasol.com**

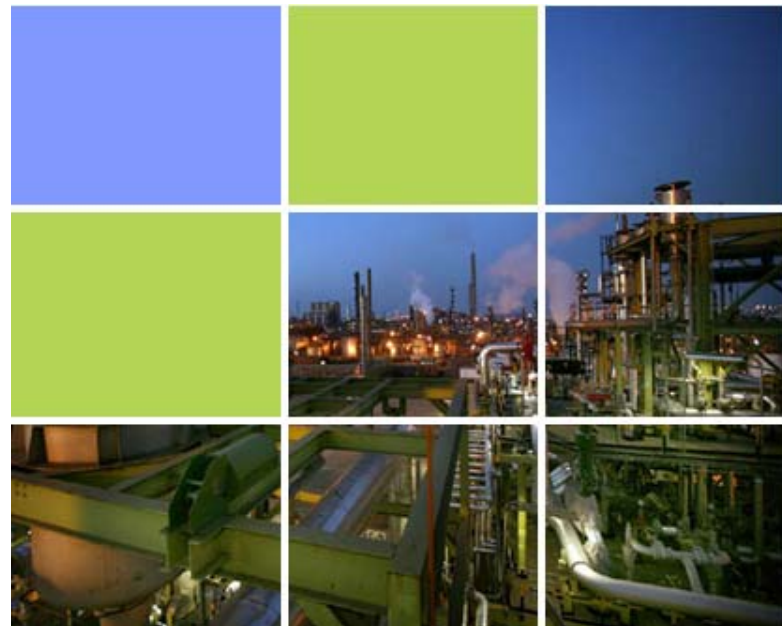

Contents

A *Update on the Sasol-Lurgi Technology Company Business Activities and the application of the S-L FBDB Gasification Technology:*

1. *Sasol-Lurgi Technology Company - Corporate Structure and Vision*
2. *S-L FBDB Gasification - Worldwide Deployments Update*
3. *SLTC's Business Landscape 2007*
4. *S-L FBDB Gasification Technology*
5. *SLTC's Global Network*
6. *In Summary*

B *Overview of Sasol's CTL Business Activities*

1. Sasol-Lurgi Technology Company - Corporate Structure and Vision

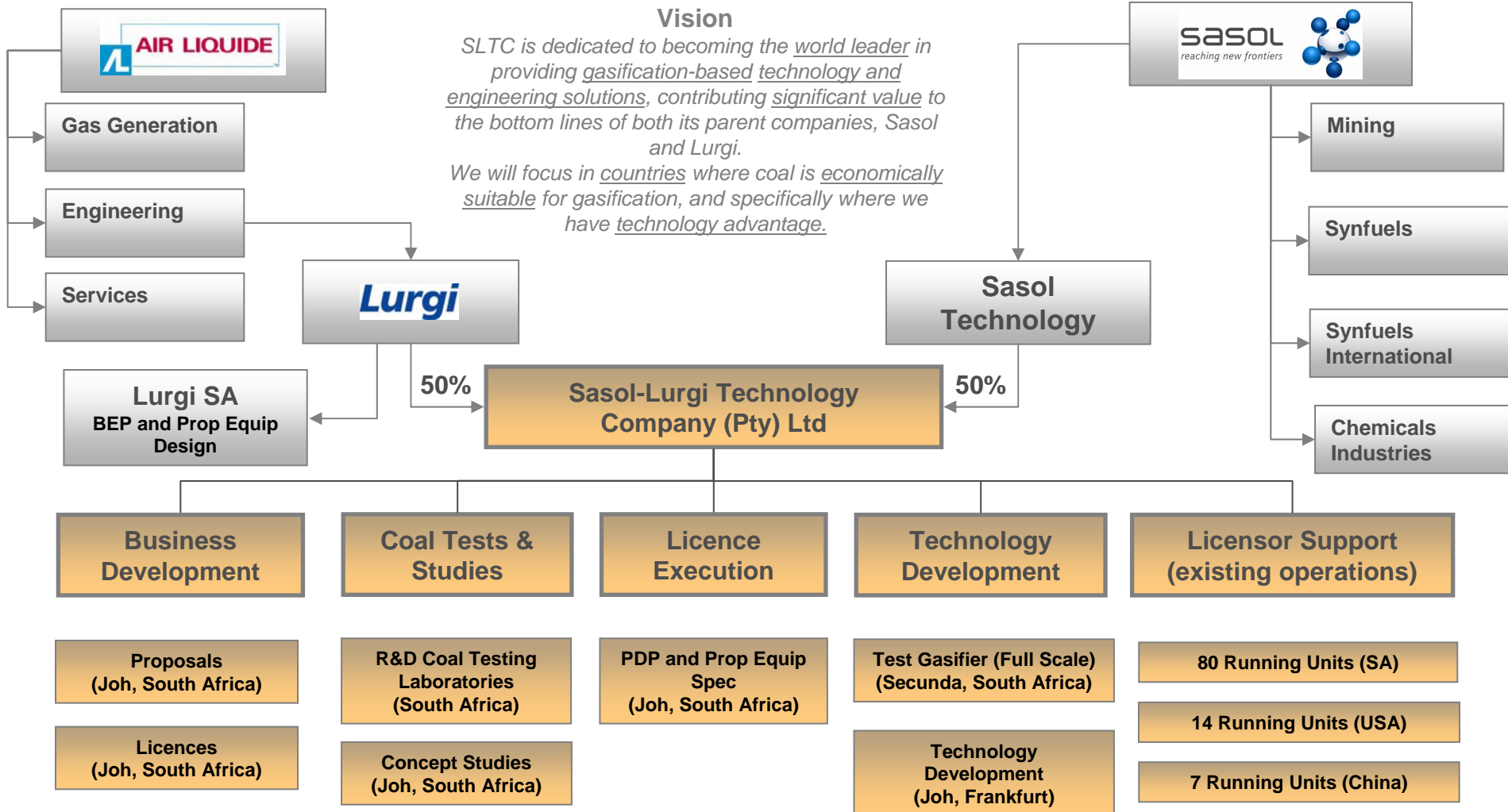



2. S-L FBDB Gasification – Worldwide Deployments Update

USA 14

China
Shanxi-Tianji Coal Chemical
Company
Province: Shanxi
5 x FBDB Units
Operation: 20 years: 1987 - 2007
Coal: Anthracite
Products: NH₃

China 7

China
Yima Coal Gasification
Province: Henan
2 x FBDB Units
Operation: 7 years: 2000 - 2007
Coal: Low rank, Sub-
Bituminous
Products: MeOH

USA
Dakota Gasification Company
(DGC)
Beulah, North Dakota
14 x FBDB Units
Operation: 22 years: 1985 - 2007
Coal: Low Rank, Lignite
Products: Sub-Natural Gas (SNG),
Phenols, Amm Sulphate, CO₂ for
EOR

South Africa 80

South Africa
Sasol Synfuels
Secunda
80 x FBDB Units
Operation: 28 years: 1979 - 2007
Coal: Low Rank, Sub-Bituminous
Products: Syngas to FT Fuels, NH₃,
Phenols, Anode Coke, Sulphur

41% of Total Global
Gasification Capacity

75% of Global Coal
Gasification Capacity

**Successful Deployment and Operation of 101 Sasol-Lurgi FBDB Gasifiers over 50years,
>20 million gasifier operating hours**



3. SLTC's Business Landscape, 2007

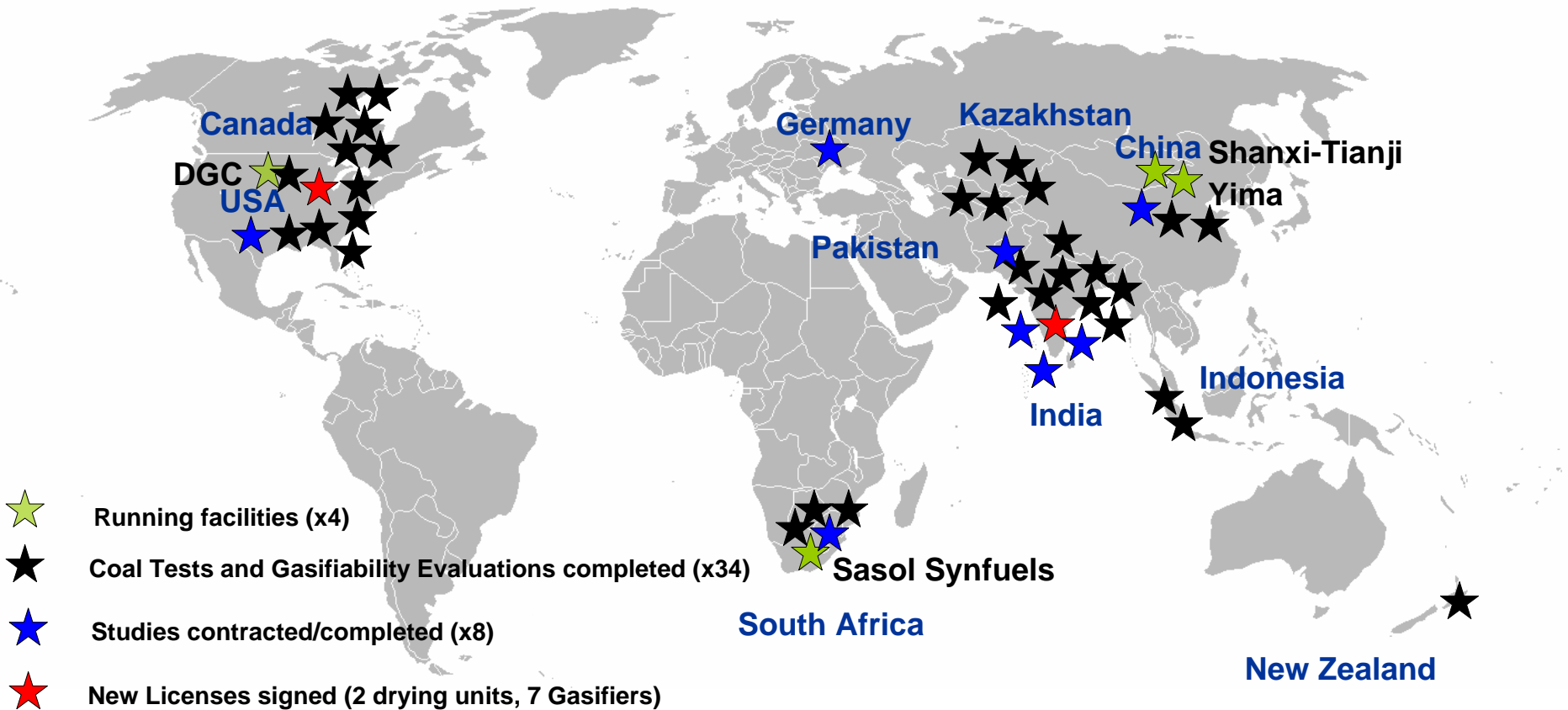

SLTC together with its affiliates are currently active on 4 Continents and in 10 Countries

3. SLTC's Business Landscape, 2007, Sasol-Lurgi in India

- @ **Client:**
Jindal Steel & Power Limited, New Delhi, India
- ❖ **Location of Facility**
Angul, Orissa, India
- ❖ **Application:**
*Syngas for Direct Reduction of Iron
 225 000 nm³/h of Syngas*
- ❖ **Coal Properties:**
Ash content ~ 37 to 42%
- ❖ **Scope of Supply**
*Basic & Detail Engineering
 Proprietary Equipment Supply
 Process Performance Guarantees
 Plant Commissioning Assistance*
- ❖ **Planned Start-up**
4th Q 2009
- ❖ **Features**
*World first integration of DRI & Coal Gasification
 Seven (7) MKIV Sasol-Lurgi Gasifiers
 Syngas Island to produce saleable ammonia, crude phenol and elemental sulphur in addition to Syngas*

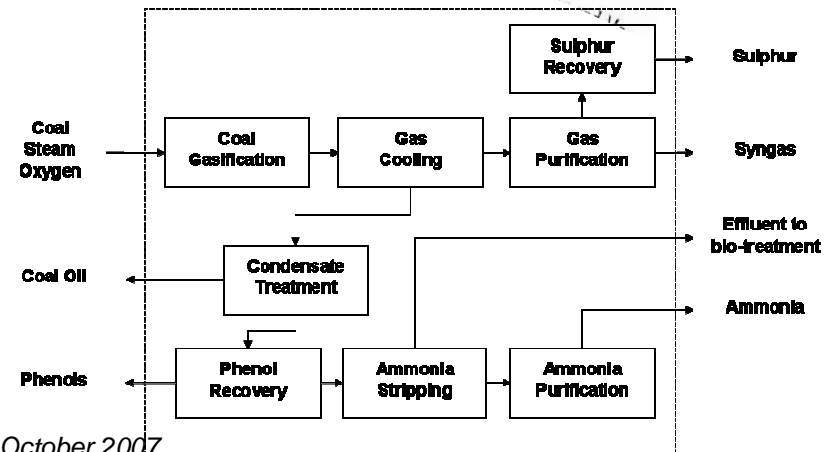



4. SLTC FBDB Gasification Technology – Crude Gas Island

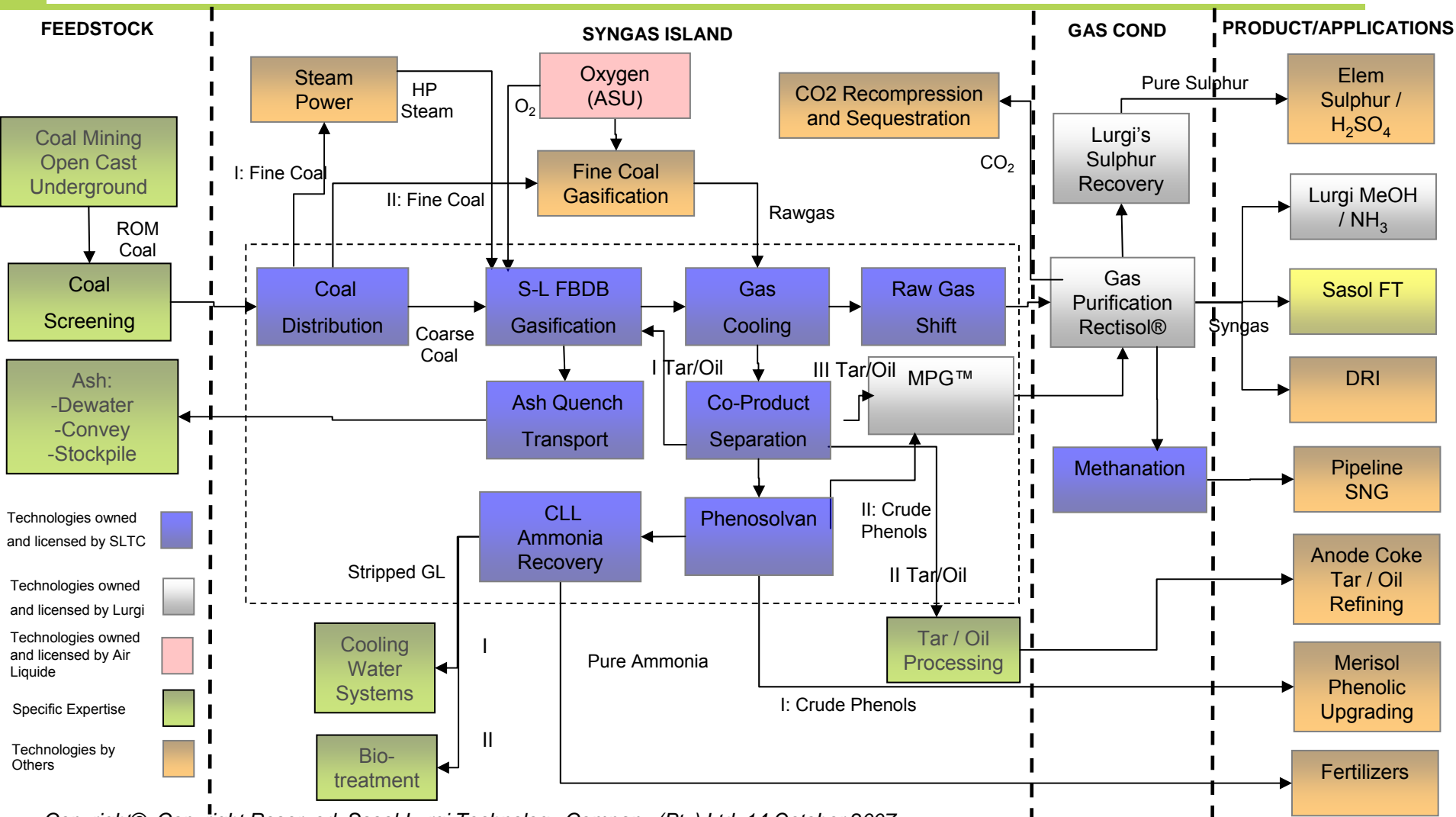



4. SLTC FBDB Gasification Technology – S-L FBDB Gasifier

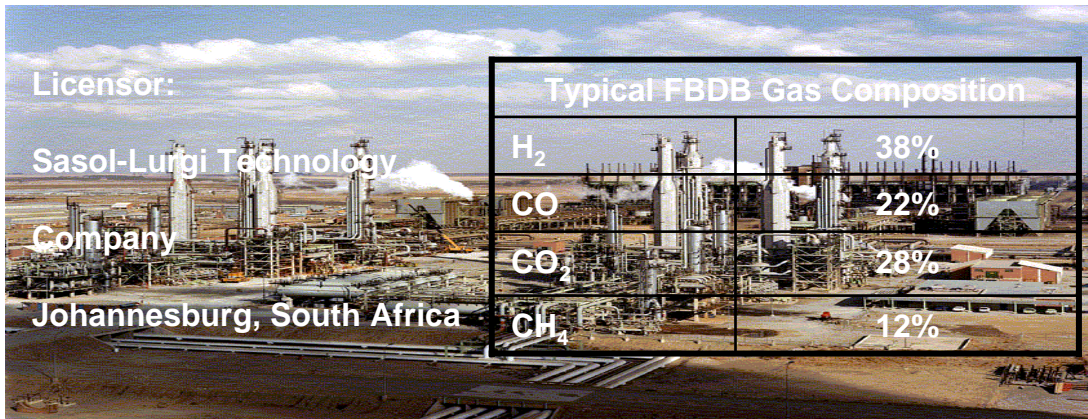

- Ash fusion temperatures at oxidizing conditions > ~1200°C
- Σ Total Moisture + Ash ~50 % w/w
- Minimum Ash Content ~4 % w/w
- Caking behavior of coal:
 - *Caking propensity will be balanced by blending of coals, or*
 - *A Coal Distributor & Stirrer will be installed*
- Biomass: 10% blend of biomass pellets with coal feed successfully demonstrated on commercial scale

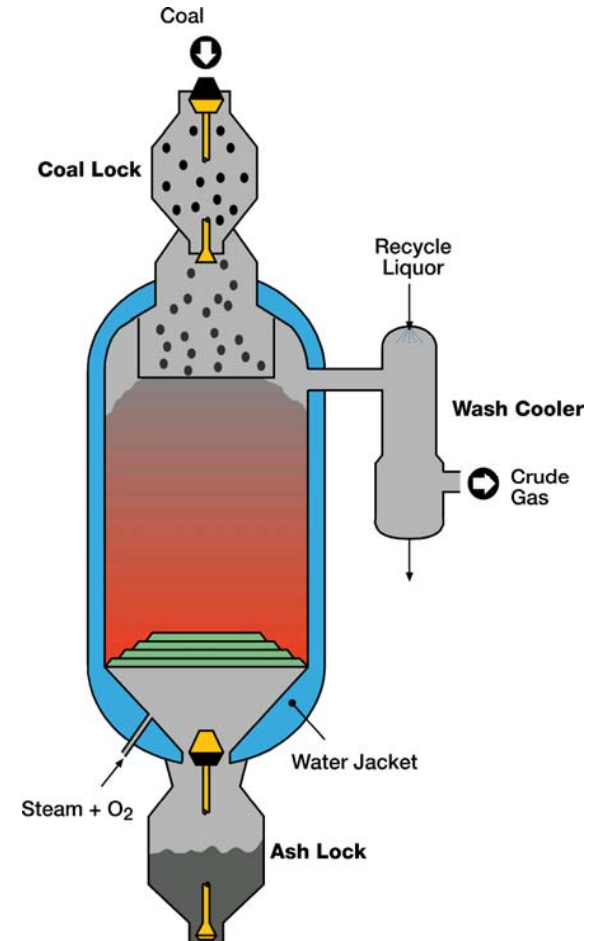

4. SLTC FBDB Gasification Technology – Gasifier Improvements

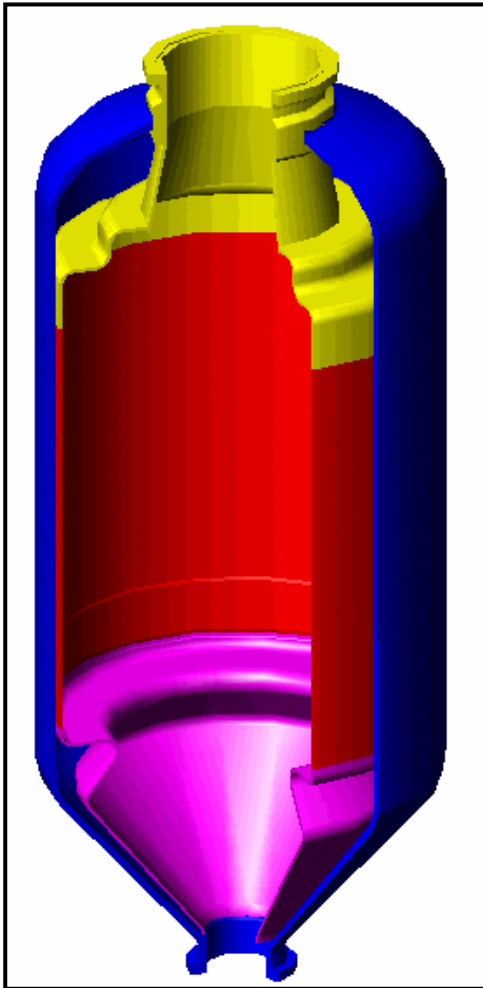

Graphic courtesy of JA Stadler – Sasol

Technology (Pty) Ltd

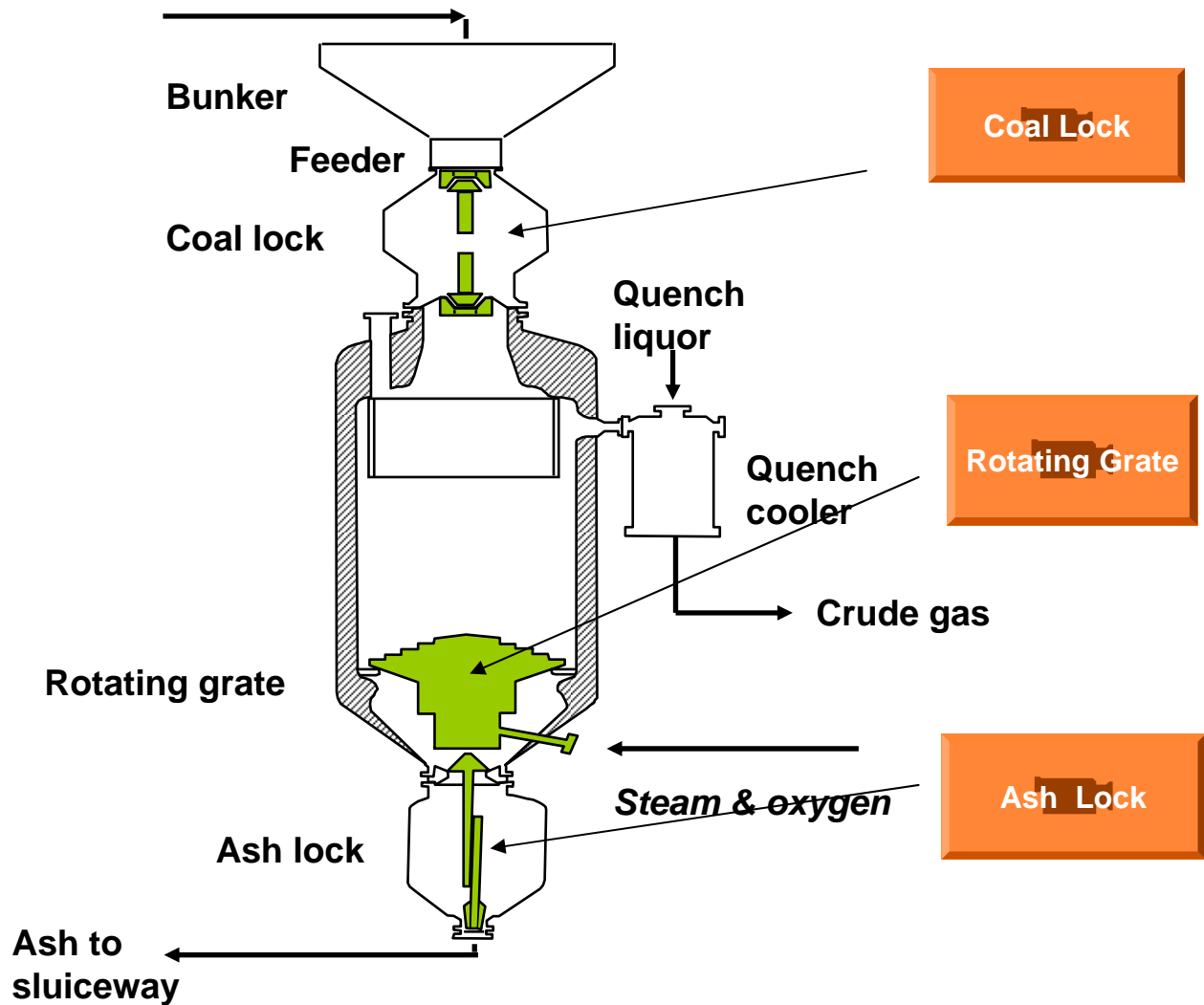



4. SLTC FBDB Gasification Technology – Development Strategy and “Extending the Operating Envelope”

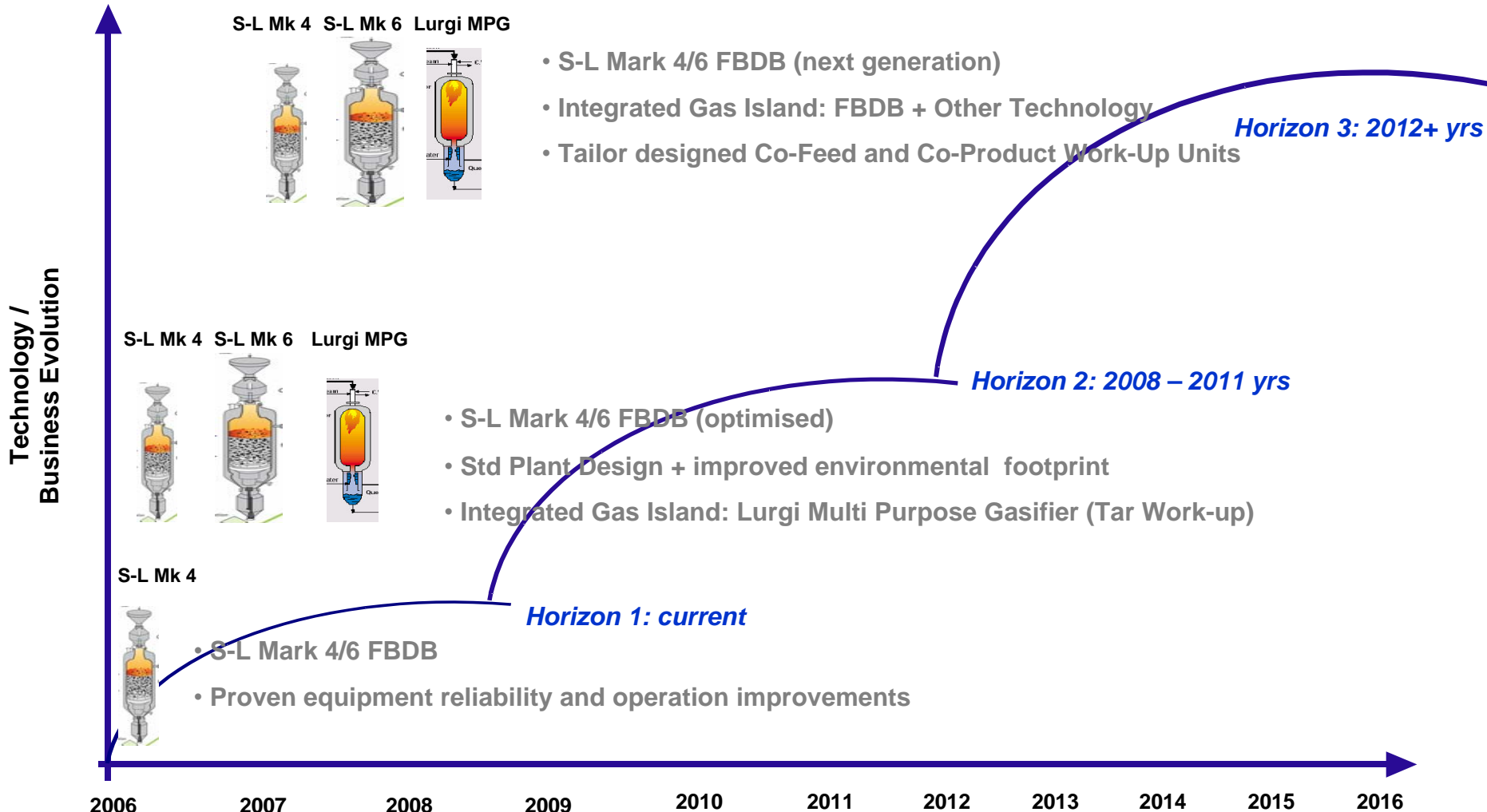

4. SLTC FBDB Gasification Technology – Gasifier Improvements

Advanced Internal Shell Design (Patented)

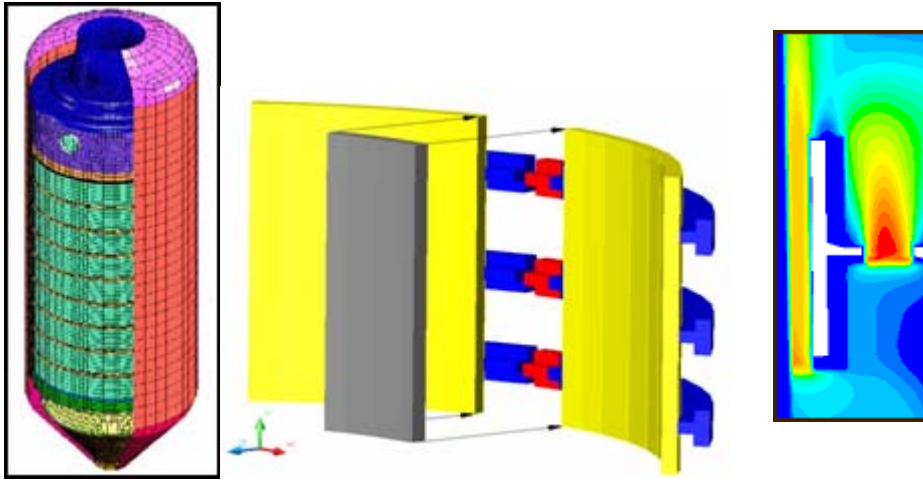

Advanced Ash Lock Valve Technology (Patented)

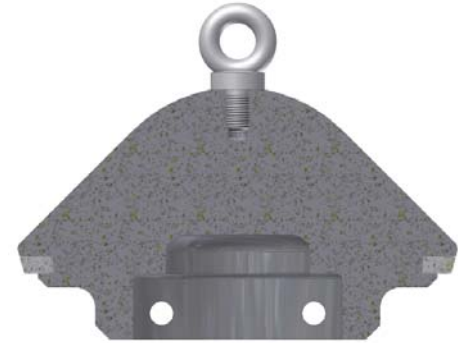

Advanced Internals for Coal Distribution & Ash Removal (Patented)

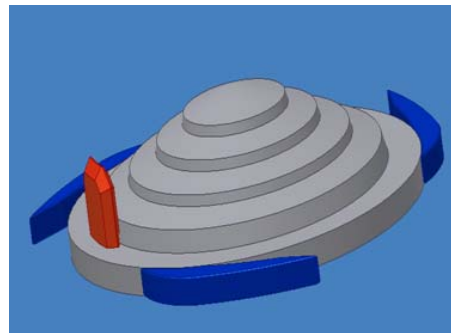
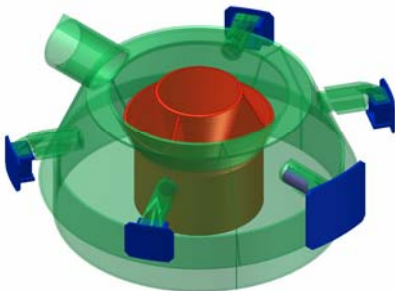

Advanced Process Modeling Capabilities

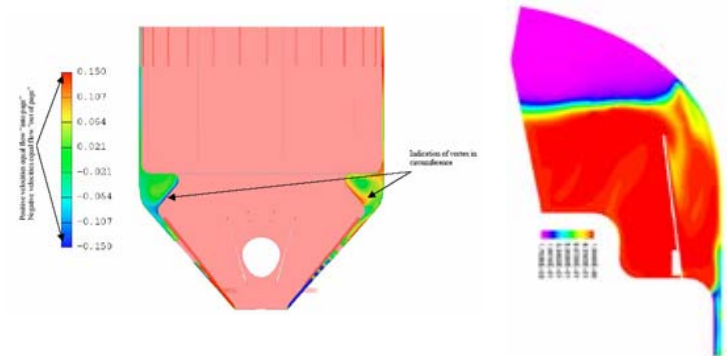

5. SLTC's Global Network

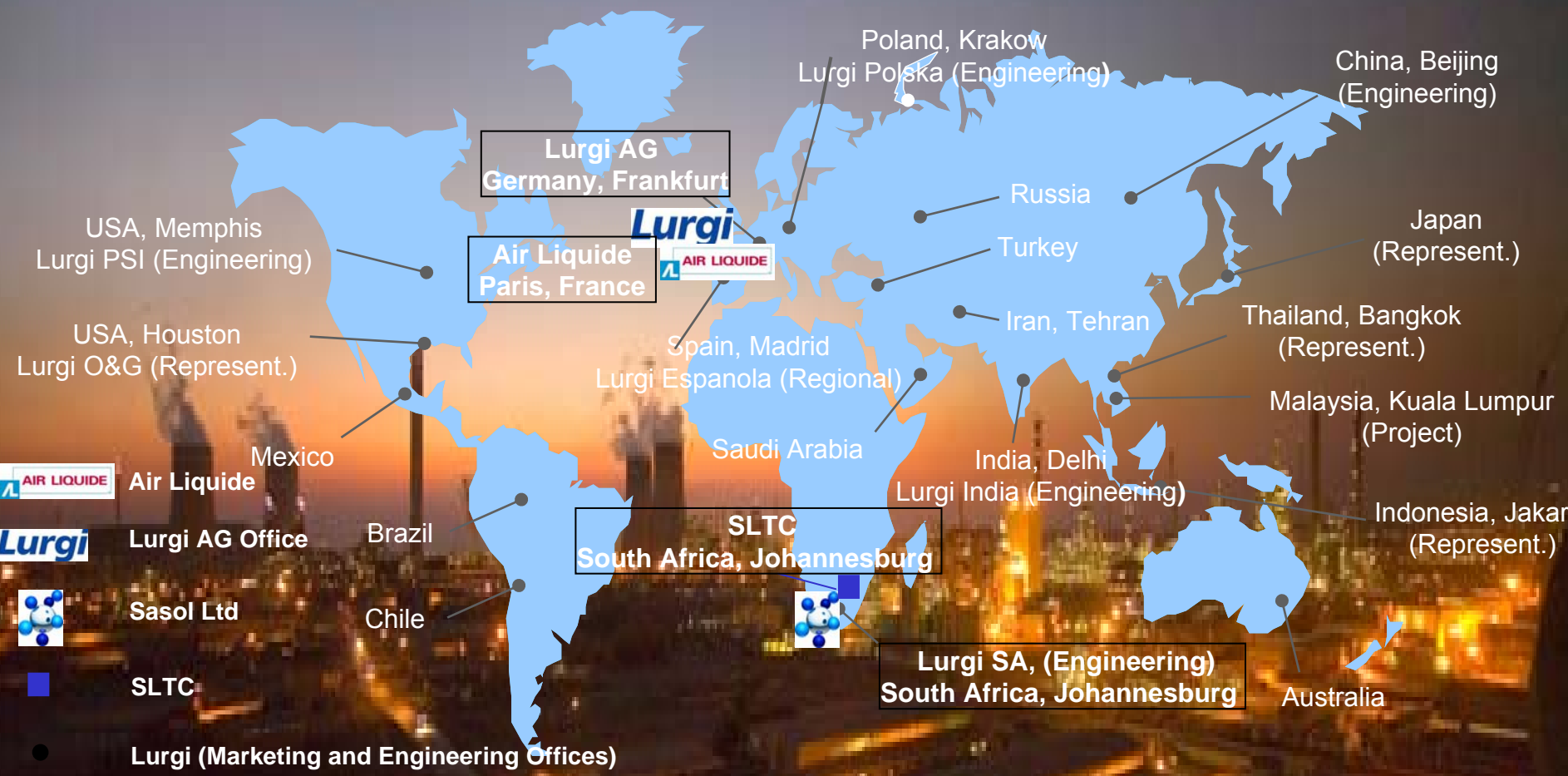

Utilising Lurgi's and Sasol's worldwide offices, SLTC can provide optimum flexibility and responsiveness in meeting our clients' project challenges

6. In Summary

In summary, S-L FBDB Gasification Technology ...

- ✓ *Ideal for countries with no oil & gas resources but low rank coals*
- ✓ *Sustain the future because low rank coal reserves exist in abundance*
- ✓ *High melting ash is an advantage to the process*
- ✓ *Flexible in the variety of products*
- ✓ *High availability by multi unit scheme, modular concept*
- ✓ *Robust process and easy to operate*
- ✓ *Advanced proprietary equipment design requiring low grade steel only*
- ✓ *Proven large scale operation with well over 50 years operational record*

SASOL
reaching new frontiers

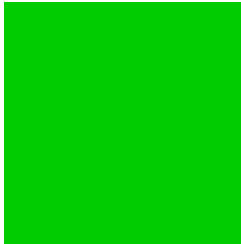

Overview of Sasol's activities in CTL

*Presentation to the:
2007 Gasification Technologies Conference
15-17 October 2007, San Francisco, CA*

*Eric van de Venter, MD SLTC
on behalf of Sasol Synfuels International*



Contents

1. *A Sasol View: Drivers Supporting the Establishment of a Global CTL Industry*
2. *Sasol's Technology Approach*
3. *CTL Products*
4. *Sasol's International CTL Activities and Projects*
5. *Conclusions*

1. A Sasol View: Drivers Supporting the Establishment of a Global CTL Industry

Why CTL could work....abundance of supply

Proven reserves of fossil fuels will sustain the world for just over 300 years at current production rates

- Crude Oil 41 years
- Natural gas 67 years
- **Coal 192 years**

Source : BP World Energy Review

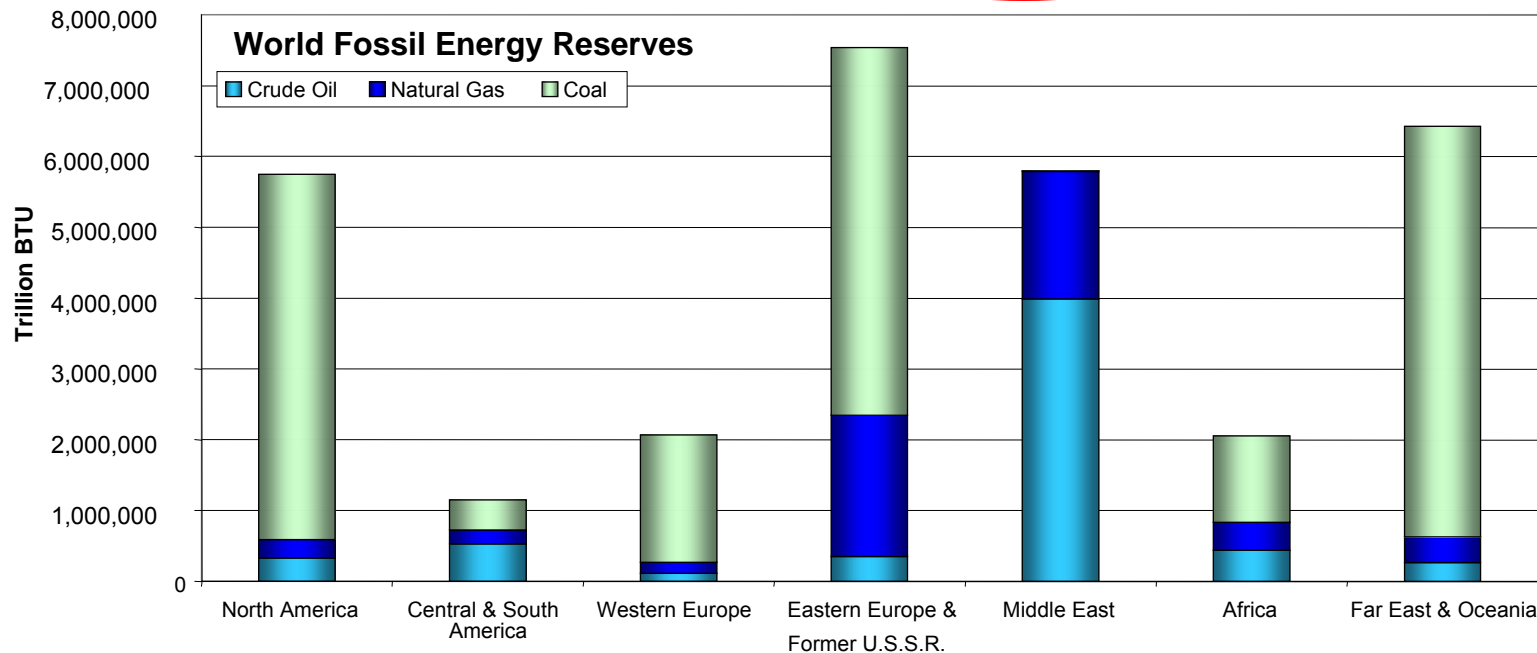

Coal will last twice as long as the combined crude oil and natural gas reserves at current usage rates



1. A Sasol View: Drivers Supporting the Establishment of a Global CTL Industry

Energy dynamics impacting competitive landscape

Escalating oil price....caused by supply constraints and increased demand resulting in....

- increased emphasis on alternatives
- renewed interest in coal use

Dr. M. King Hubbert's prediction in 1956 that U.S.oil production would peak in about 1970 and decline thereafter was scoffed at then ...but his analysis has since proved to be remarkably accurate.

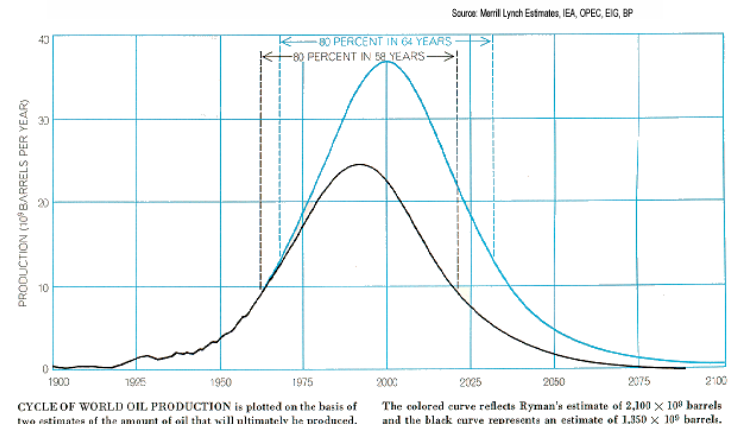
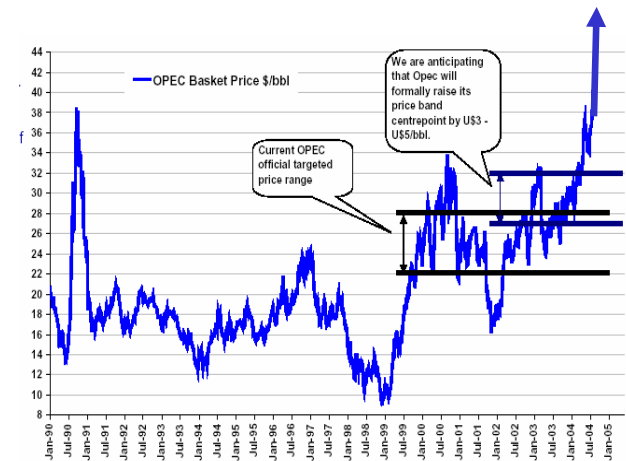



1. A Sasol View: Drivers Supporting the Establishment of a Global CTL Industry

- Access to :
 - *low cost, gasifiable coal (a minimum of approximately 2 – 4 billion tons).*
 - *“stranded coal” (due to location or quality) which can not be easily monetised in other ways.*
 - *adequate water resources close to proposed site.*
- *Major energy consumer, i.e. net importer of energy.*
- *Low construction costs.*
- *Locality to large attractive markets.*
- *Clear GHG emission directives, and opportunities for CO2 solutions*
- *Enabling legislation.*



2. Sasol's Technology Approach - Fischer Tropsch (FT) Technology, an Enabler for GTL and CTL

Main GTL Drivers

Abundant, inexpensive hydrocarbon reserves (coal, natural gas, biomass)

Global drive for cleaner transportation fuels

+

FT Technology

+

Main CTL Drivers

Diversity of energy supply

Reduced dependence on crude oil



2. Sasol's Technology Approach - Sasol's Processes Convert "Locked-in" Resources to Easily Transportable Liquid Fuels

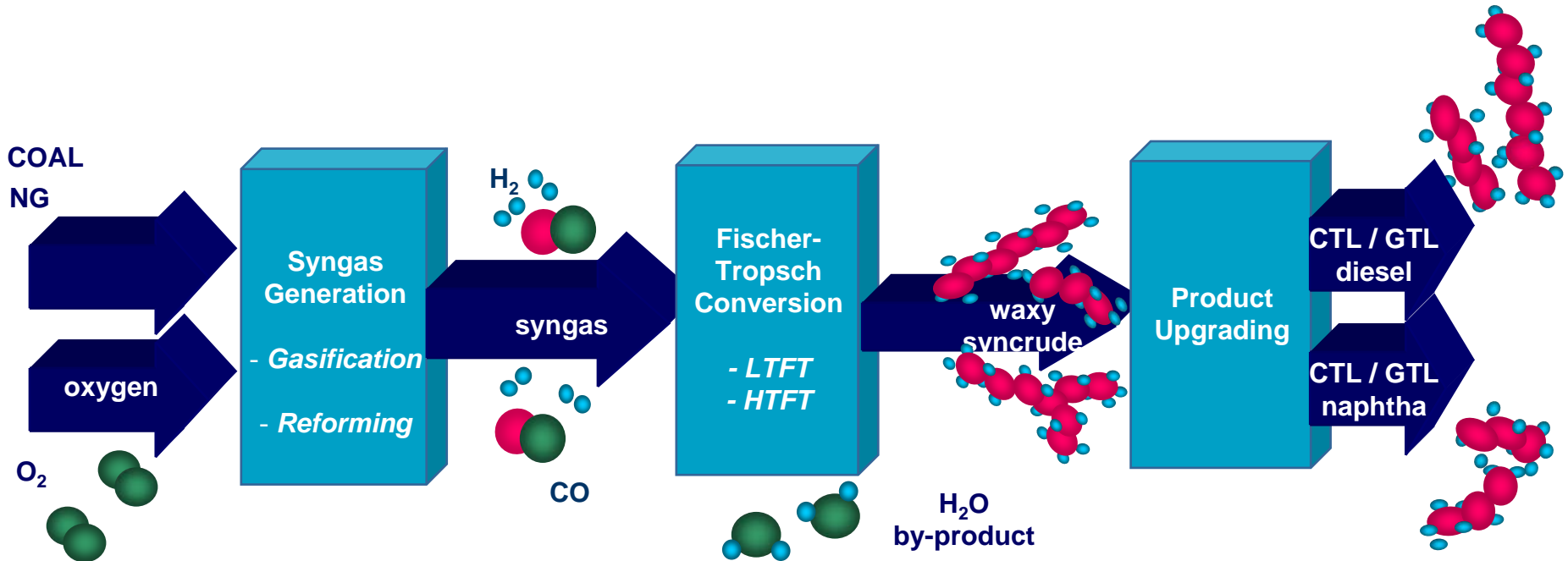

	Low Temp Fischer Tropsch (LTFT)	High Temp Fischer Tropsch (HTFT)
Diesel	√	√
Gasoline	n/a	√
Jet Fuel	√	√

3. CTL Products – Synthetic Fuels

Diesel	LTFT Derived	HTFT Derived
Specifications	Conforms to proposed ASTM Low Temperature FT specifications Can conform to D1 specification	Conforms to ASTM D975, can conform to CARB (CARB T90<321)
Sulphur	<5ppm (ultra low)	<5ppm (ultra low)
Cetane	>70	48-55
Aromatics	<1% (highly paraffinic)	10 - 25%
Density	>0.77 kg/m ³	0.81 kg/m ³
Cloud Point	< -17 °C	< -12 °C
Application	Blend component or niche applications	Market

Gasoline	LTFT Derived	HTFT Derived
Sulphur	No gasoline in product slate	<5ppm
Octane/Octane Index		Will comply to market requirements
Aromatics		10 - 25%
Olefins		10% (CARB) or 18% EN 228 (Europe)
Benzene		< 1%
Oxygenates		Allowed

Kero/Jet Fuel	LTFT Derived Kero	HTFT Derived Kero/Jet A1
Specifications	Component approval in process	Allowed up to 50% with conventional Jet A1 as semi synthetic jet fuel Await approval for full synthetic jet fuel – end 2007 Will enable JP8
Sulphur	<5ppm	<5ppm (Full synthetic)
Aromatics	<2%	8 – 25% (Full synthetic)



3. CTL Products – Synthetic Fuels Offer Advantages Over Crude Oil Derived Fuels

Synthetic Diesel

- *ultra low sulphur - <5 ppm*
- *highly paraffinic - <1% total aromatics*
- *very high cetane number - >70*
- *lower density - ~0.77 kg/l*
- *good cold flow properties*
- *compatible with existing materials used in engines*

Synthetic Naphtha

- *ultra low sulphur content*
- *high in paraffins*
very low aromatics
low octane number
- *high hydrogen content*
- *highly linear molecules*
- *ideal for cracker feedstock*

... and are compatible with existing systems & engines

3. CTL Products - Sasol CTL Synthetic Jet Fuel, Exhaust Emission Test

Comparison of NO_x Production for Sasol Fuel and Conventional Jet A

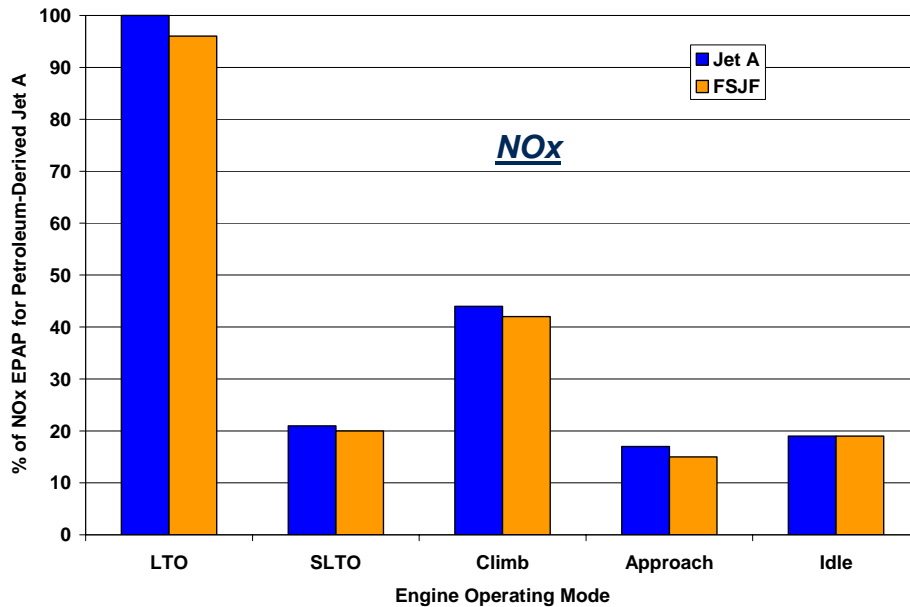

Note: LTO – Land Take Off, SLTO – Simulated Land Take Off
The Environmental Protection Agency parameter (EPAP) is the total amount of pollutant created per unit of net thrust from the engine.

Comparison of CO Production for Sasol Fuel and Conventional Jet A

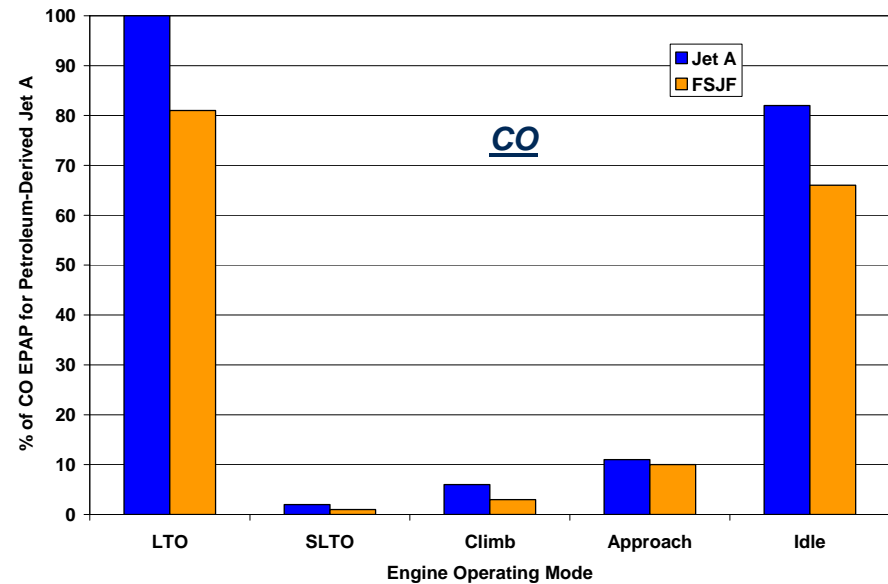

Note: The Environmental Protection Agency parameter (EPAP), which is regulated by ICAO, is the total amount of pollutant created per unit of net thrust from the engine (F00).



3. CTL Products - Exhaust Emission Benefits: Diesel Passenger Cars

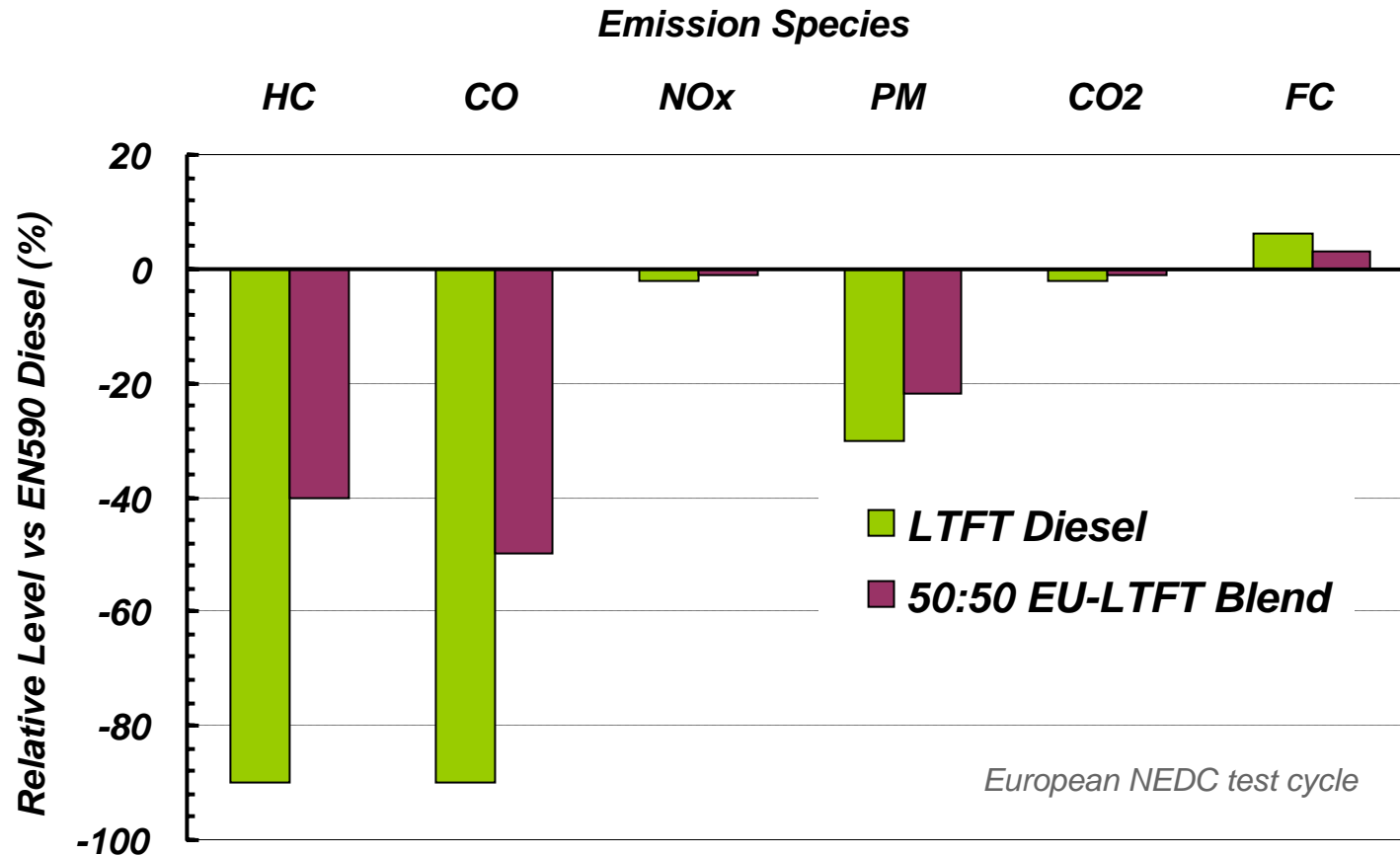

> 90% reduction in CO and HC



4. Sasol's Current International CTL Activities and Projects - Synfuels Industry in South Africa today

Sasol II & III (CTL)

- *Capacity: 150 000 bbl/d crude oil equivalent*

Mossgas (GTL)

- *Capacity: 45 000 bbl/d crude oil equivalent*

Total Capacity : 195 000 bbl/d crude oil equivalent



...Synfuels Industry supplies 30% of total current SA fuel consumption



4. Sasol's Current International CTL Activities and Projects

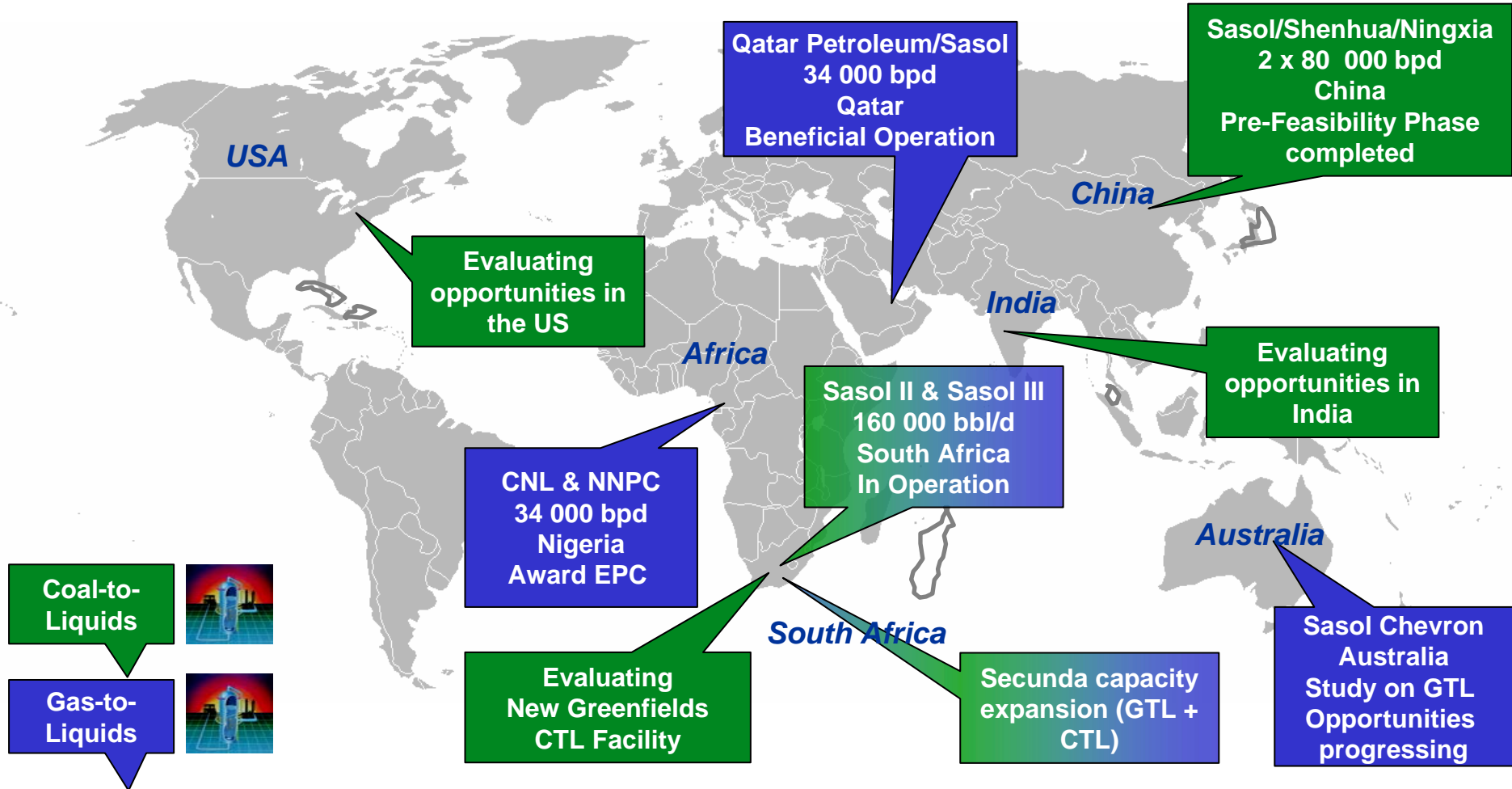



4. Sasol's Current International CTL Activities and Projects - China CTL Project Overview



Two Sites identified

- *Ningxia Autonomous region*
- *Shaanxi province*

Pre-feasibility Study to evaluate these projects completed - moving into next phase

Typical world-scale CTL plant:

- *2 X 80,000 BPD nominal capacity*
- *Main product: Diesel*



3. Sasol's International CTL Activities and Projects - USA coal supply regions being considered

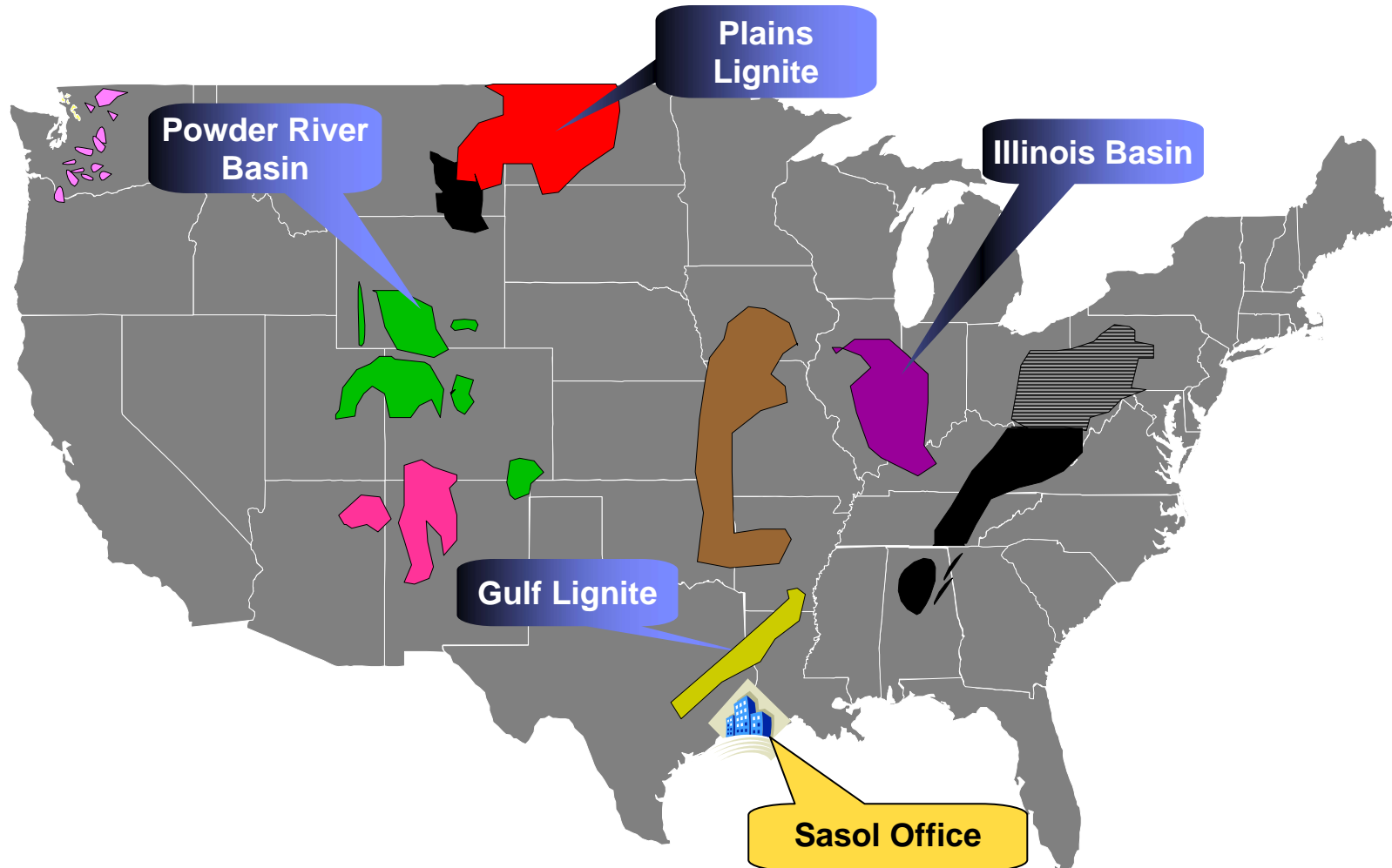



3. Sasol's Current International CTL Activities and Projects - Targeted CTL Locations in India

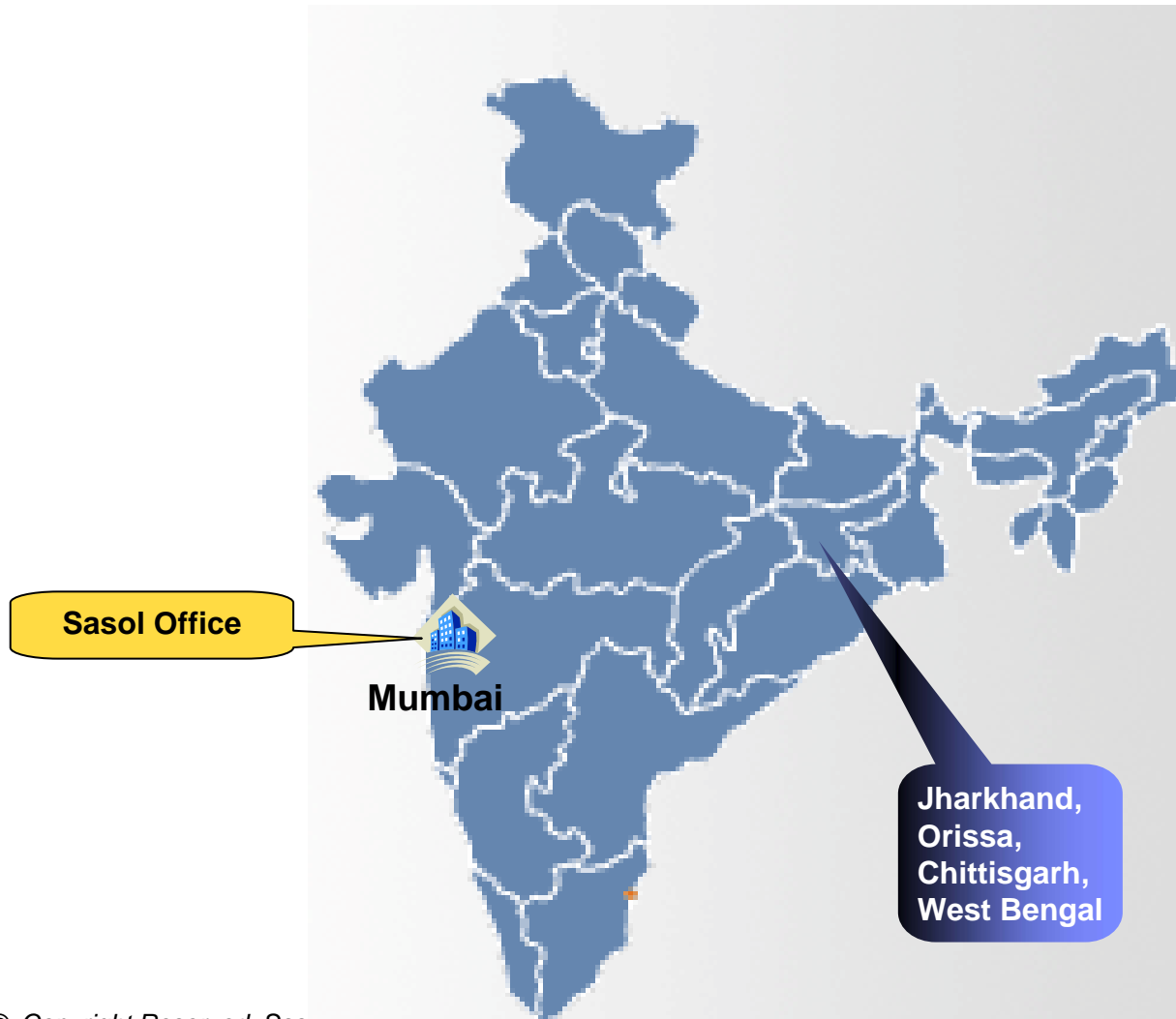



5. Conclusion

- *CTL is already proven at commercial scale in RSA*
- *CTL Industry requires initial government support & involvement:*
 - *Enabling*
 - *Protection*
- *Sasol's Technologies provide low risk route to a domestic deployment*
- *FT derived fuels are already meeting future fuel specifications*

