

IGCC FUJIAN PROJECT

Dario Camozzi - Snamprogetti, Italy
Andrea Baldelli - Snamprogetti, Italy
Sun Hong – Sinopec Ningbo Engineering Company, China

Gasification Technologies 2007

San Francisco, October 14-17, 2007

Fujian Refining and Ethylene Project

The Fujian Refining and Ethylene Project foresees

(Quanzhou, Fujian Province, China)

- The revamping of the existing refinery from 4 to 12 million tons-per-year.
- A new 700 kT/Y PX aromatic complex.
- A 800 kT/Y ethylene plant.
- Other petrochemical plants.
- An IGCC Plant.

Joint Venture Participation

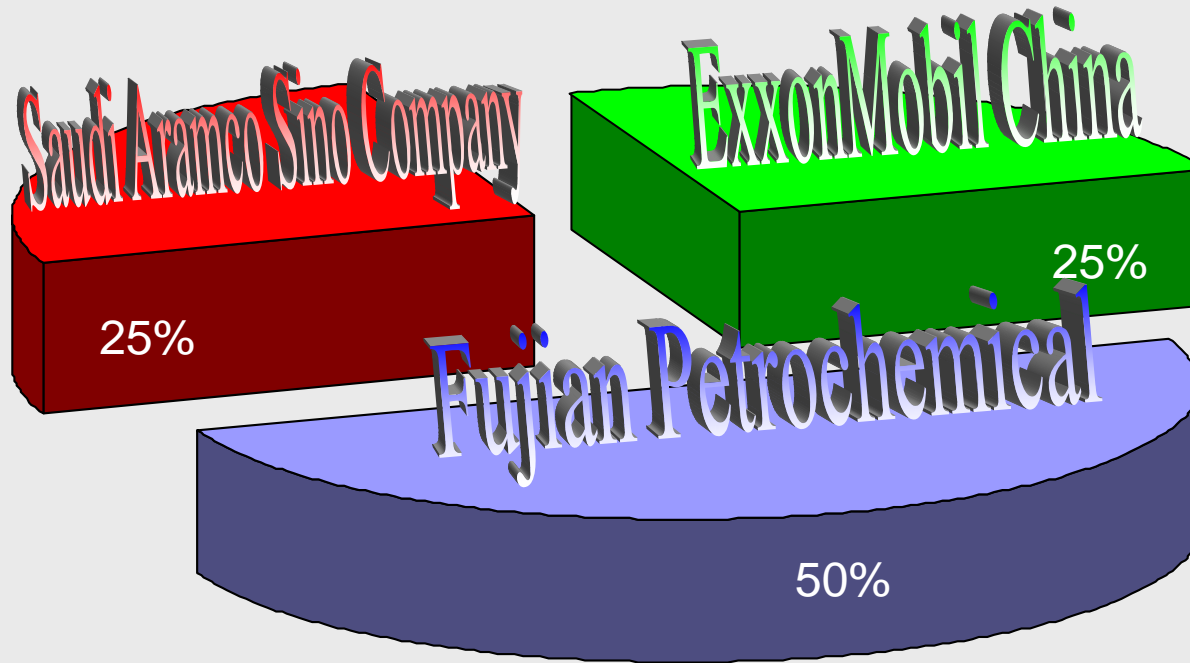

Joint Venture Participation

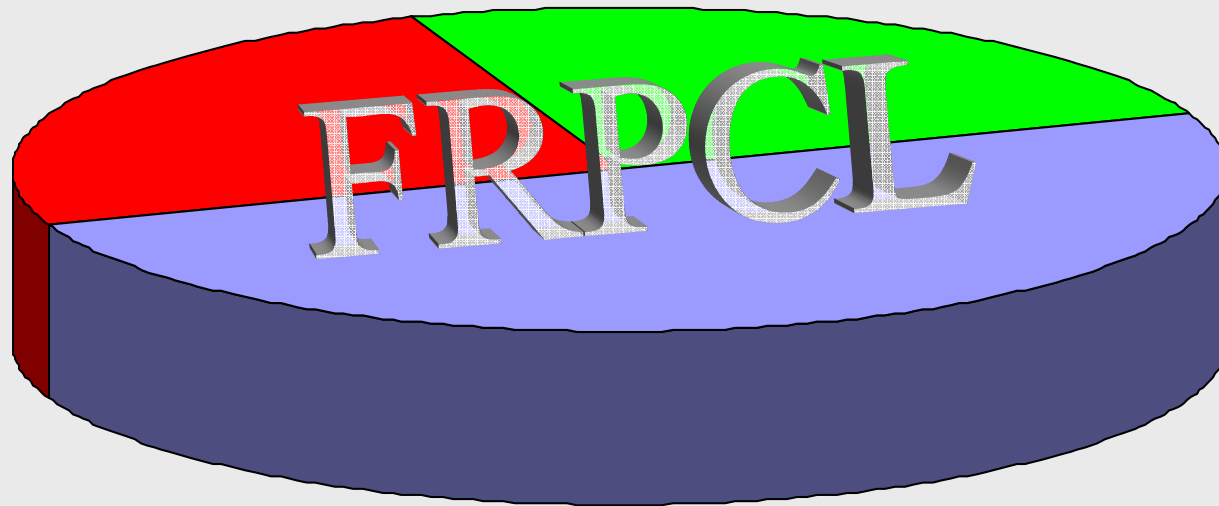

IGCC Project Management contract (PMC)

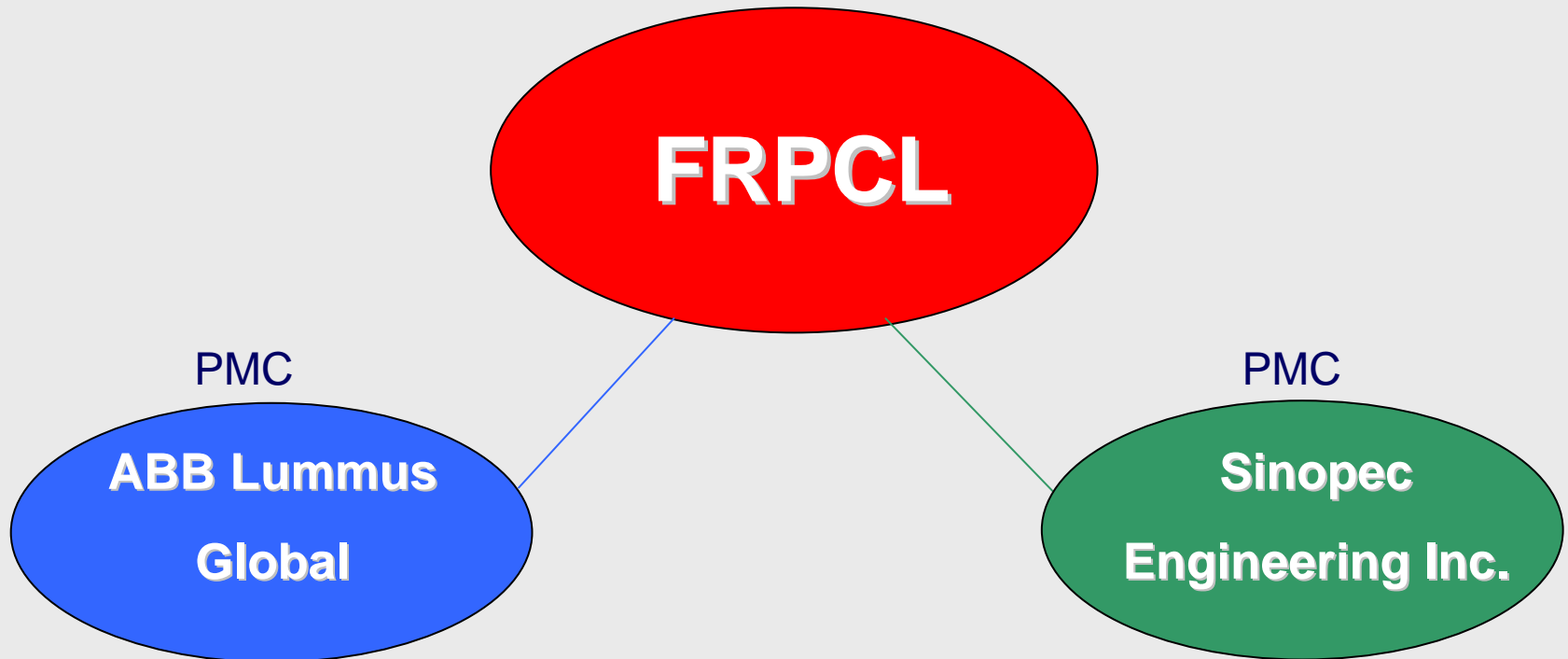

Management scope:

- Management and Coordination of Technology Licensors
- Open-art process design packages
- Management of detail engineering, procurement, construction and start up

Fujian IGCC Plant



The Fujian IGCC complex will be the first fully integrated plant in China and one of the largest oil-based IGCCs in the world.

Fujian IGCC Plant

The IGCC plant

is based on partial oxidation licensed by **Shell Global Solutions**,

Main characteristics:

- ✓ Hydrogen production: 80,000 Nmc/h
- ✓ Steam production: 5136 (11MPa)T/d 7.7(3,7MPa)T/d
- ✓ Power production : 280 MW

IGCC Project Main contractor

Main Contractor

SNEC

Sinopec Ningbo Engineering
Company Limited

China

Main Contractor Partner

Snamprogetti SpA

Italy

Technical support for:

- Air Separation Unit
- Partial oxidation
- Acid gas treatment
- Procurement Services

Main Contractor Partner

Tecnicas Reunidas

Spain

Technical support for:

- Cogeneration Unit
- Procurement Services

Main Contractor for FEED and EPC phases

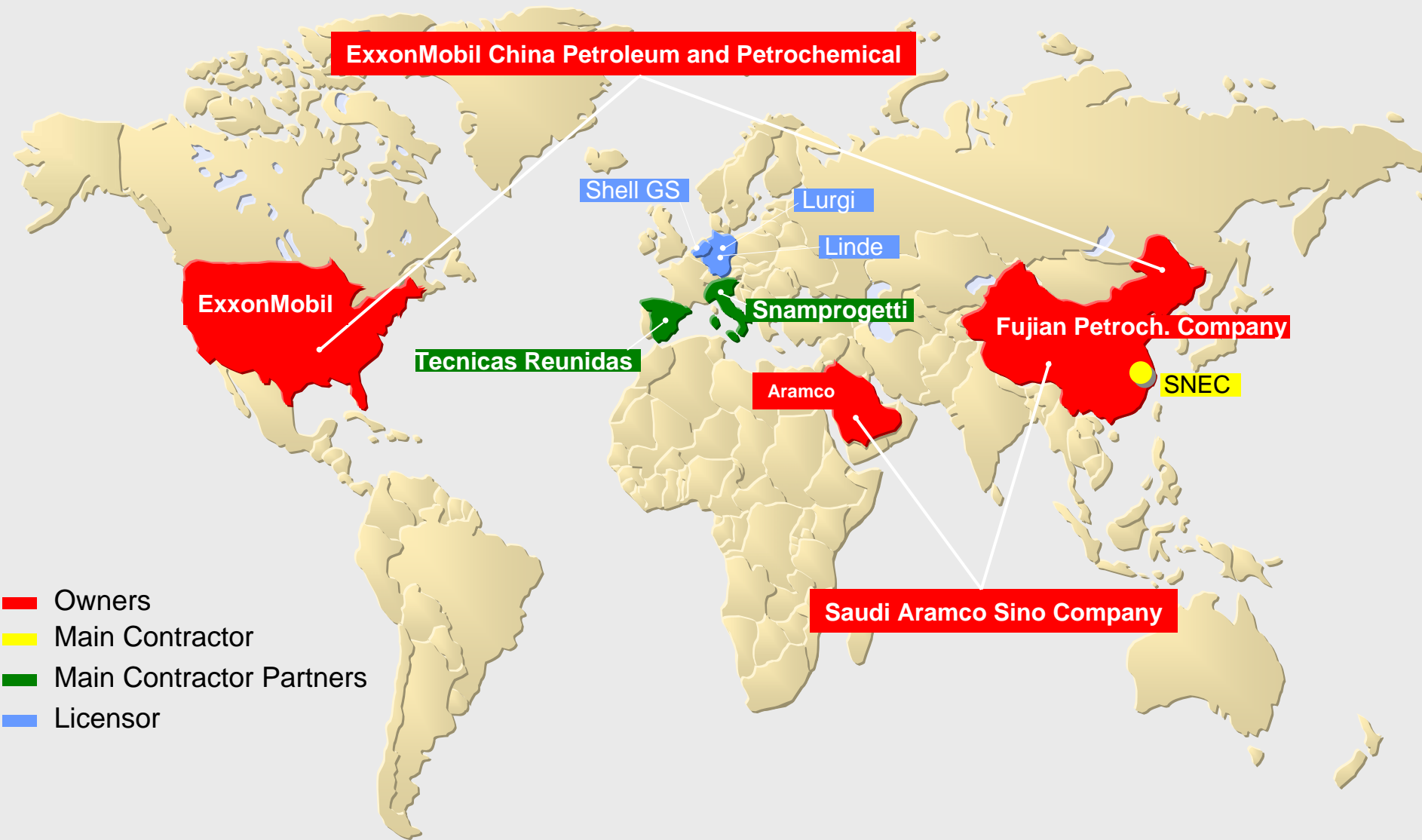

- Owners
- Main Contractor
- Main Contractor Partners
- Licensor

Fujian IGCC Plant Process Block Diagram

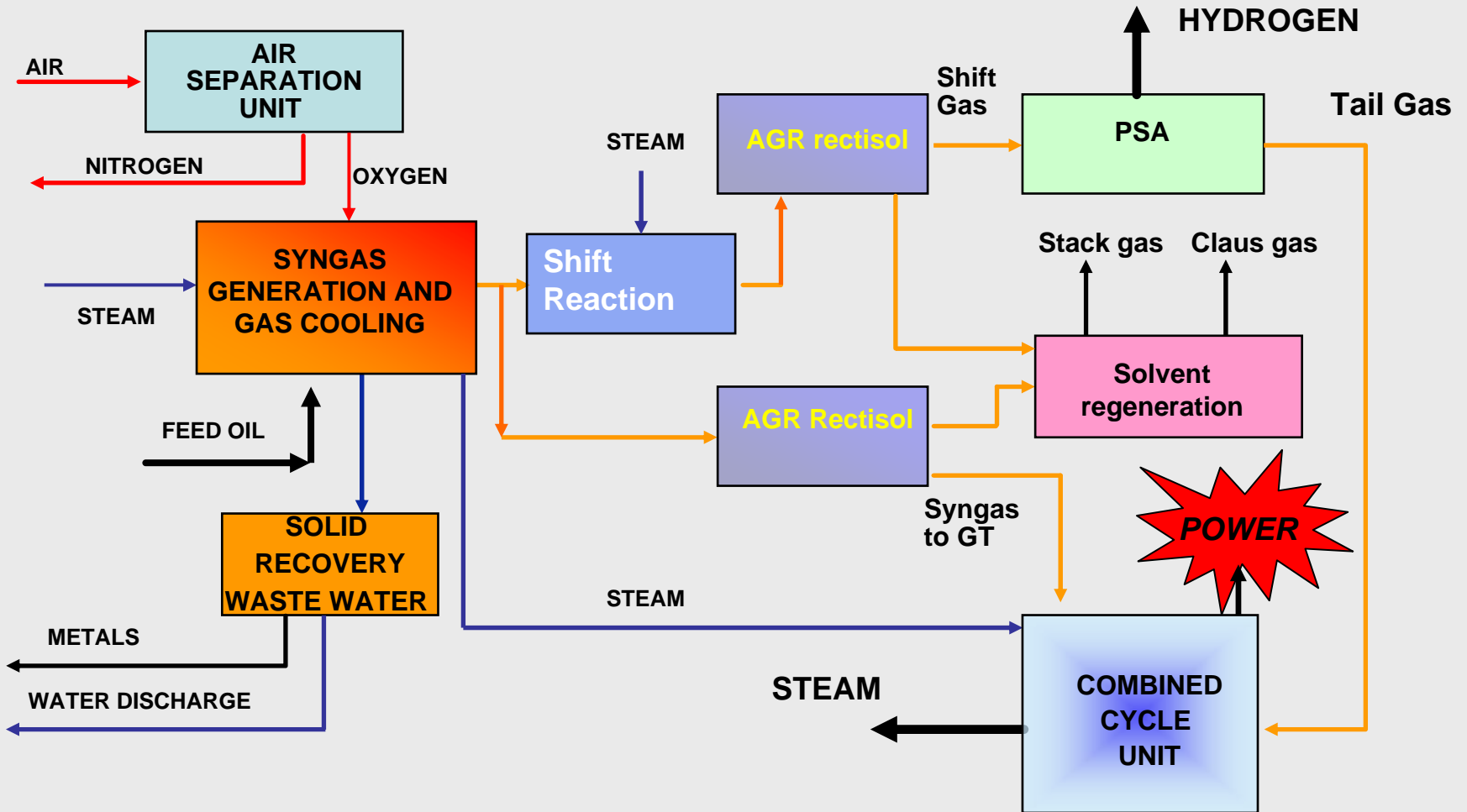

Fujian IGCC Plant Air Separation

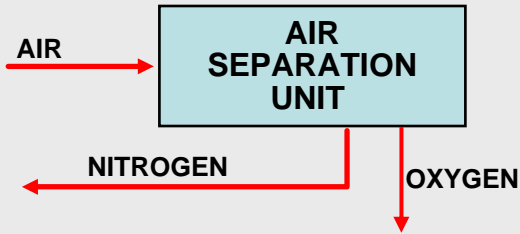

Main Features:

Oxygen Production: 1200 T/d

Oxygen purity: 99.8%

Number of train: 2

Licensor: Linde

Fujian IGCC Plant Gasification

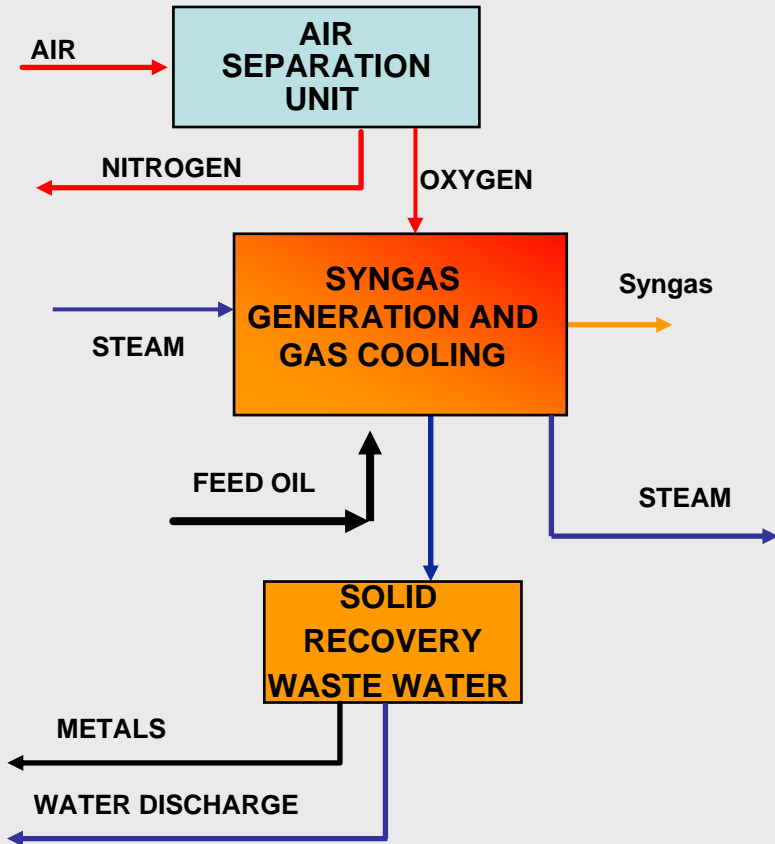

Main Features:

De-Asphalted rock: 2177 T/d(rated)
2400 T/d(design)

Data on Dry	%wt maf	Data on Dry	%wt maf
Carbon	84.01	Nitrogen	1.00
Hydrogen	8.02	Sulfur	6.82
Oxygen	0.15	Ash	0.18

Syngas Production: 4850 T/d(rated)

	% mol		% mol
CO ₂	4.21	COS	0.08
CO	50.17	N ₂	0.35
H ₂	43.14	Ar	0.05
CH ₄	0.27	HCN NH ₃	82 ppm
H ₂ S	1.55	H ₂ O	0.18

Train number: 3 (one hot stand by)

Licensor: Shell Global Solution

Fujian IGCC Plant

Shift reaction

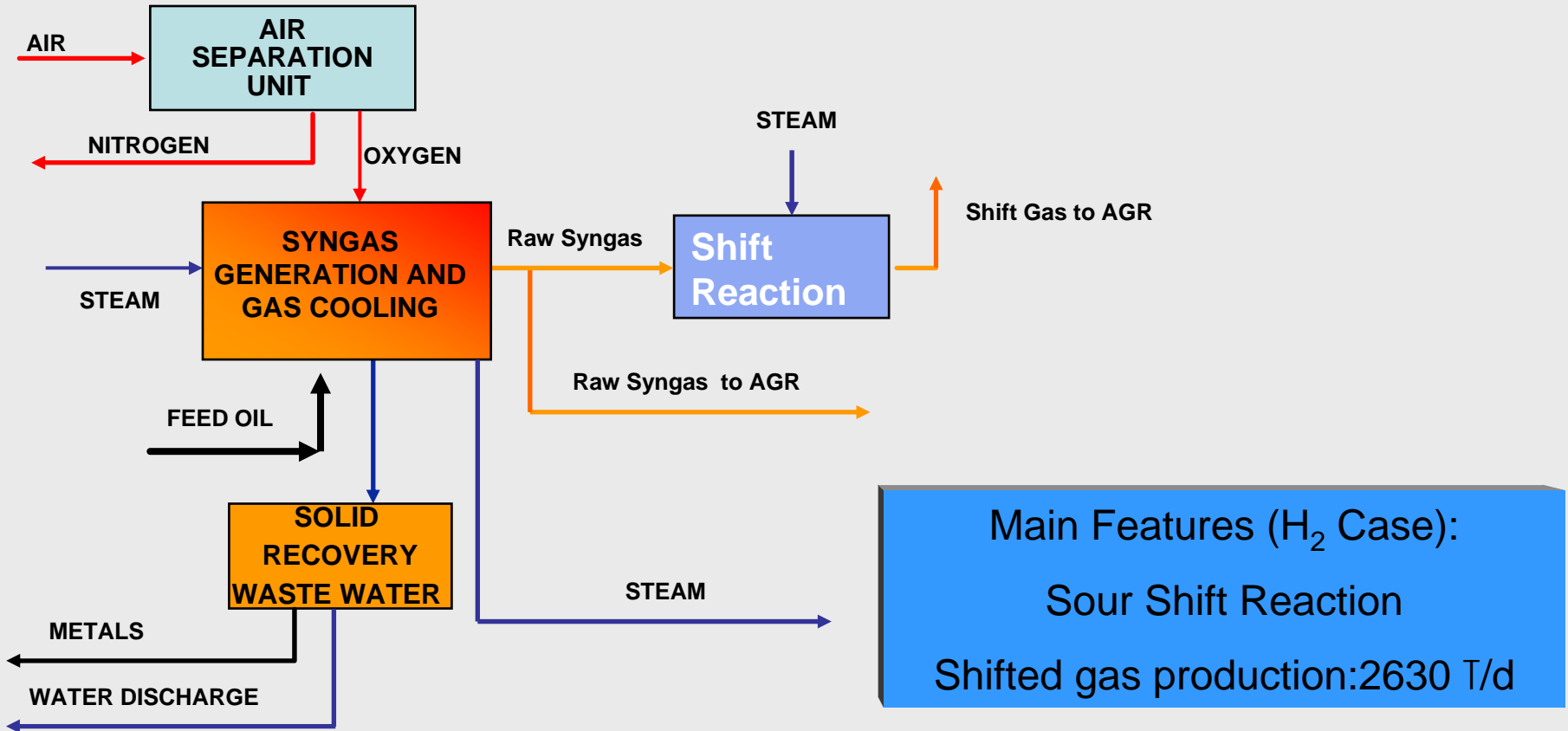

Fujian IGCC Plant Acid Gas Removal

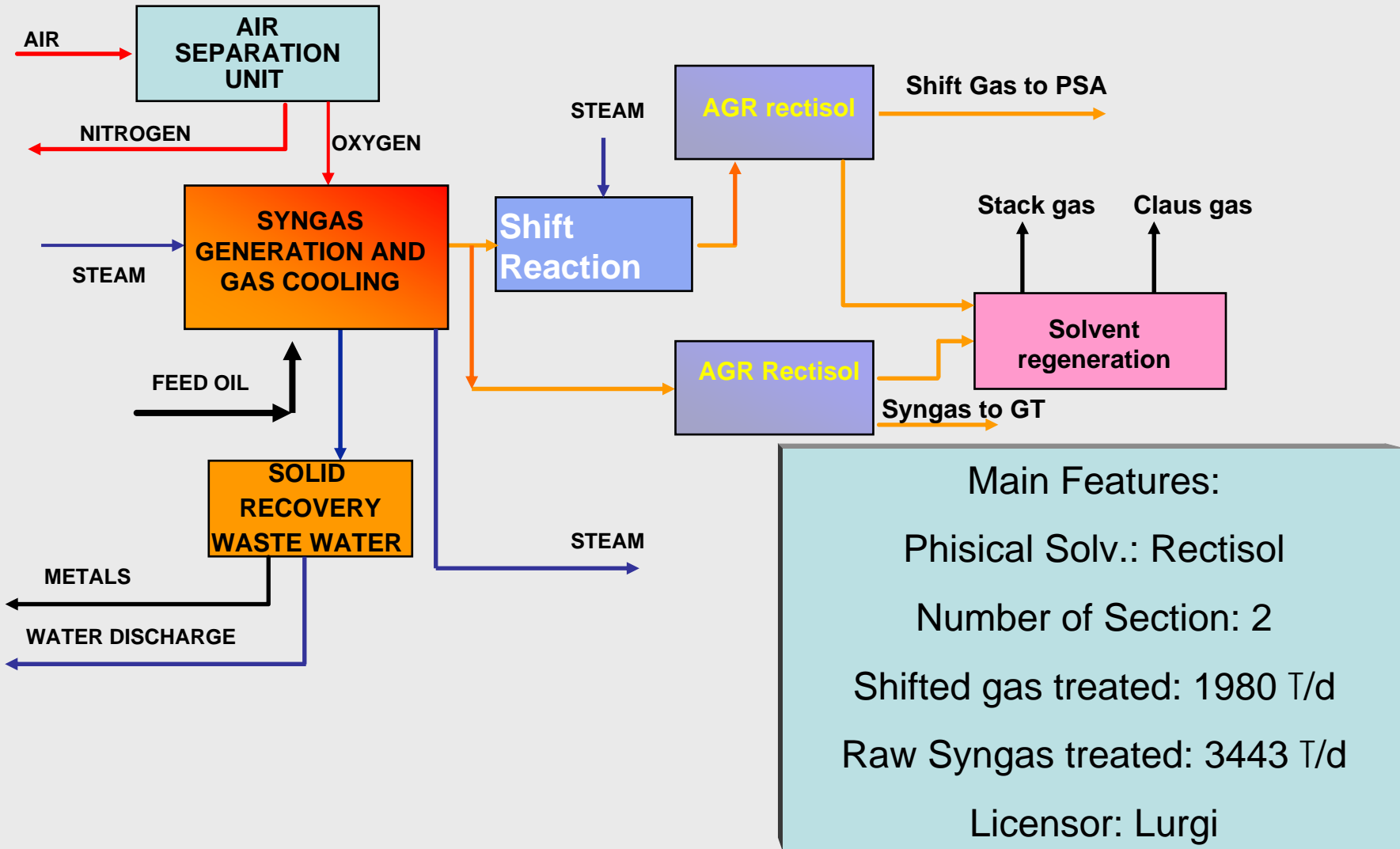

Fujian IGCC Plant PSA

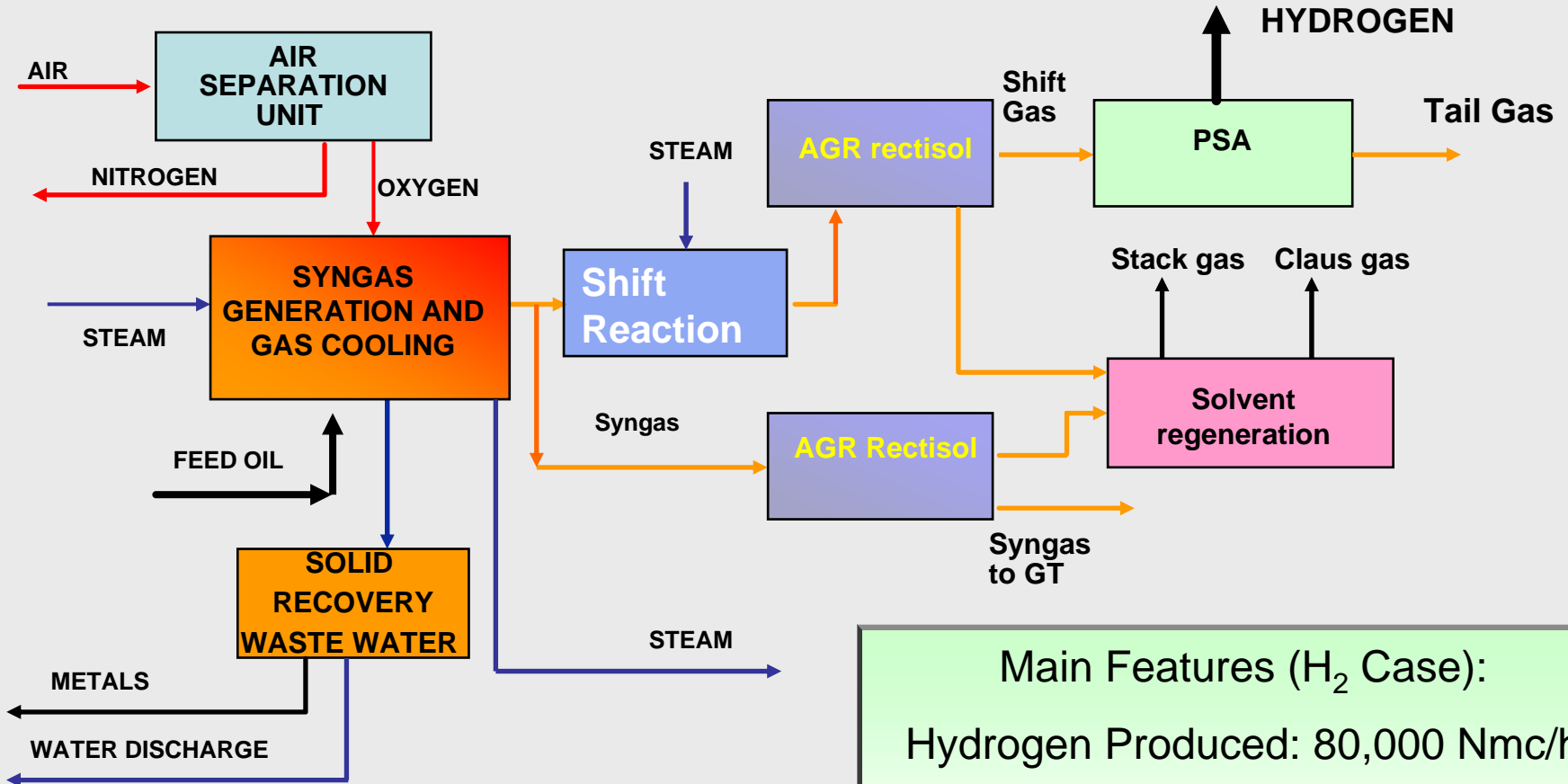

Main Features (H₂ Case):
 Hydrogen Produced: 80,000 Nmc/h
 PSA Yield > 90%
 Tail gas used as fuel in Boilers

Fujian IGCC Plant Combined Cycle

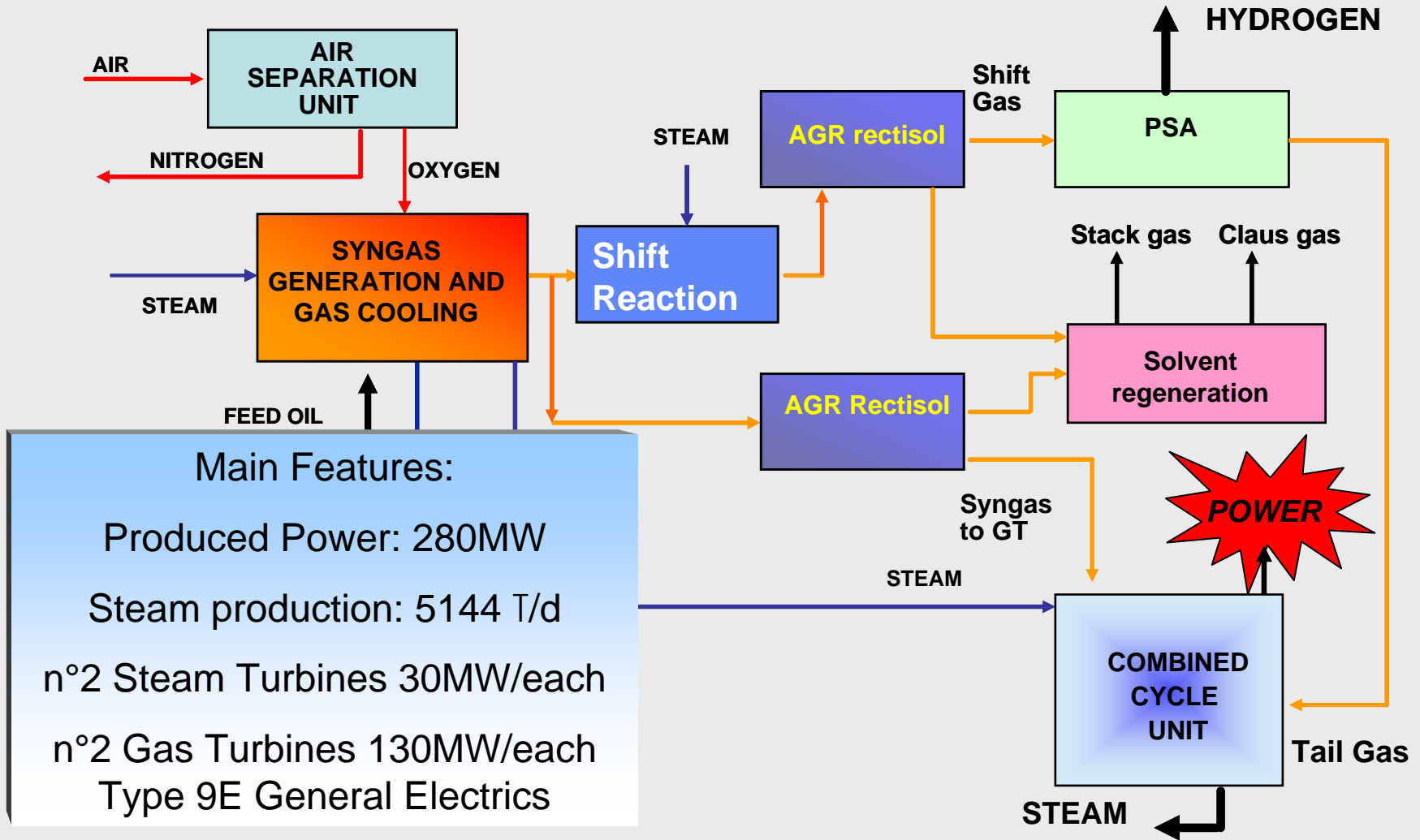

Fujian IGCC Plant

Project Schedule

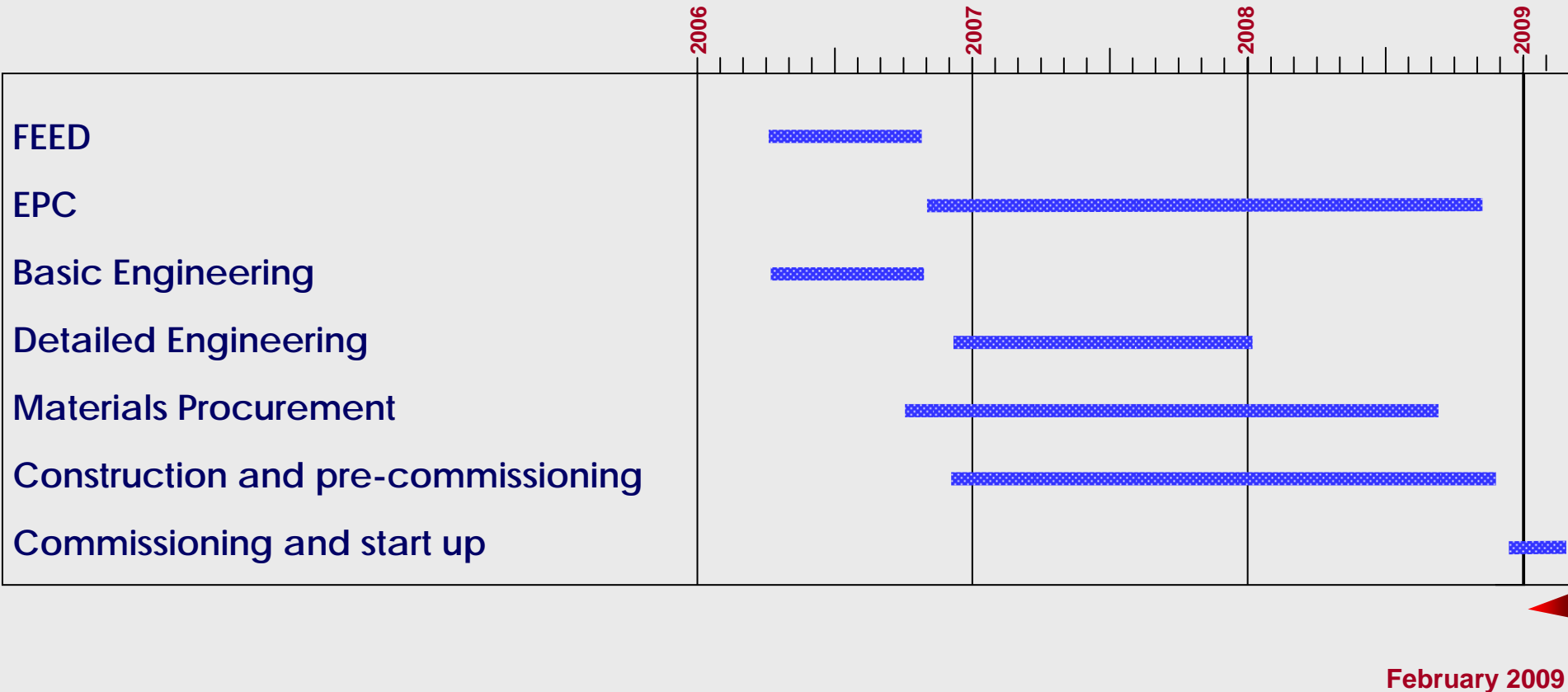

Fujian IGCC Plant

Plant construction



THANKYOU

Snamprogetti SpA

Dario Camozzi
Technical Manager

Phone: 39-02-52043640

Fax: 39-02-52053504

e-mail: dario.camozzi@snamprogetti.eni.it